

## Power Management of Hybrid System (PEMFC/PV/ Lithium-ion Batteries) Using State flow

Y. Hanafi<sup>1</sup>, K. Mammar

<sup>1</sup> Smart Grid and renewable energy Laboratory  
University of Béchar Bp 417 08000 Béchar- Algeria.

\*Corresponding author: yaiche.hanafi@gmail.com; Tel.: +213 68 21 41 52

### ARTICLE INFO

#### Article History :

Received : 31/01/2022

Accepted : 07/09/2022

#### Key Words:

Photovoltaic (PV) system;  
Power management;  
Controller;  
DC load;  
Fuel cell;  
Energy storage;  
Stateflow.

### ABSTRACT/RESUME

**Abstract:** For this article, we propose a power management controller for a hybrid system; the study of the model proposed includes a fuel cell, a PV, a lithium-ion battery, and a catalyst to produce Hydrogen. Furthermore, the control system of the active power uses the Stateflow approach. This study gives an easy scheme of the power management controller and a practical code to implement the target hardware. The state flow controller is used to equalize the energy flow inter the system's elements. At first, to simulate these elements, MATLAB Simulink software is used, then all modes of operation of this controller using Stateflow are detailed. This paper showed that the management of the power source flow could use the Stateflow approach as an efficient alternative means.

### I. Introduction

Straightforwardly, the Lack of Fossil fuel causes the necessity to find other energy resources possessing the same characteristics as fossil fuel concerning its capacity and supply. Hydrogen is a great candidate, and it can be combustible in the fuel cell field. although it's just an energy vector and not a pre-existing source, the alternative energy sources produce Hydrogen [1].

Therefore, envisioned that Water electrolysis powered by renewable energy like solar and wind improve hydrogen production, with no emissions of CO<sub>2</sub> during the water electrolysis processes. Consequently, aggregating excess renewable energy as Hydrogen gives incredible opportunity. Hydrogen formed from this process has excellent purity of about 99.9% and can be used as combustible in fuel cells [2].

Proton-Exchange Membrane Fuel-Cell, PEMFC is an Electrochemical device that can convert a portion of Hydrogen's chemical energy into electrical energy. it is the electrochemical combustion of Hydrogen and oxygen that produces electricity, water, and heat [3].

PV source is an intermittent source of energy, and its

production depends on time, sunlight, and weather conditions. So, a secondary source is necessary for the efficient use of PV. Furthermore, in the nighttime, PV can't produce any energy. So, batteries are needed to store surplus energy during the daytime. PEMFC has an excellent potential to be a green energy source considering its good efficiency [4]. Therefore, this paper finds the PV-PEMFC system as a practical solution to benefit from both friendly sources of energy for their advantages.

The greatest disadvantages of PEMFC are very sensitive and costly materials[5]; One of the major disadvantages of the hybrid system is the high cost of the battery often comes as a problem [6].

The hybrid system, which uses PEMFC with PV and Lithium-ion Batteries, is preferred for the production of continuous energy throughout the year every day for 24Hours/24Hours [7].

This paper uses the State flow approach to control the energy management system for a hybrid system, PEMFC with Lithium-Ion battery, all together PV to supply a DC load. The principal objective of such management is to cover the Photovoltaic generator power, issued intermittently [8].

**II. Modeling Components**

The structure of the complete system shown in Figure 1, is primarily built on the middle BUS. while the Direct-Current BUS linked all power sources, storage, and load [4].

The system consists of alternative power sources (photovoltaic modules/array and PEMFC). A boost power "DC/DC Converter" is used to adjust voltage between PV array generator and common Bus; batteries to compensate for the unpredictable PV-produced power and the charge's power demanded; two Buck-Boost regulators used for controlling the flow of energy to/from the battery pack and power flow to/from the PEMFC. An electrolyzer generates Hydrogen in the case of excess PV's power [8].

With SIMULINK@MATLAB software the power controller is simulated. From the literature, more details about intermediate electronic devices can be taken[9–12].

**II.1. Template PEMFC Model**

The Proton-exchange membrane fuel-cell (PEMFC) is the converter that transforms a section of chemical energy of fuel into electricity; the precept is very simple same as reverse electrochemical electrolysis; it is a reaction between oxygen and hydrogen that produce water, heat energy and electricity as given in the equation (1) [13-14].

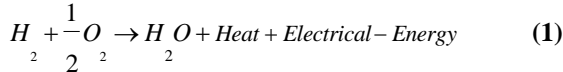

According to the following reaction at the anode (2), we see hydrogen oxidation; and protons transfer via the membrane onto the cathode.

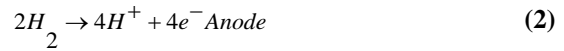

Equation (3) describes Oxygen reduced at the cathode:

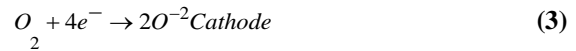

Equation (4) gives the form of the PEMFC output voltage.<sup>15</sup>

$$V_{FC} = E_{act} - V_{Ohm} - V_{Con} \quad (4)$$

$$V_{FC} = 1.229 - 0.85 \times 10^{-3} (T - 298.15) + 4.31 \times 10^{-5} T \left[ \ln \left( \frac{P_{H_2}}{P_{O_2}} \right) + \frac{1}{2} \ln \left( \frac{P_{O_2}}{P_{H_2}} \right) \right] + \left[ \xi_1 + \xi_2 T + \xi_3 T \cdot \left( \frac{C_{O_2}}{C_{H_2}} \right) + \xi_4 \ln \left( \frac{I}{I_{stack}} \right) \right] + B \cdot \ln \left( 1 - \frac{j}{j_{max}} \right) - I_{stack} \left( \frac{tm}{S \cdot \sigma} + R_c \right)$$

Where:  $V_{FC}$  is the output voltage of a fuel cell stack (V).  $E$  : is the fuel cell stack internal potential;  $V_{act}$  is the overall activation voltage drop (V);  $V_{ohm}$  is the overall ohmic voltage drop (V) and  $V_{Con}$  is the overall concentration voltage drop [13].

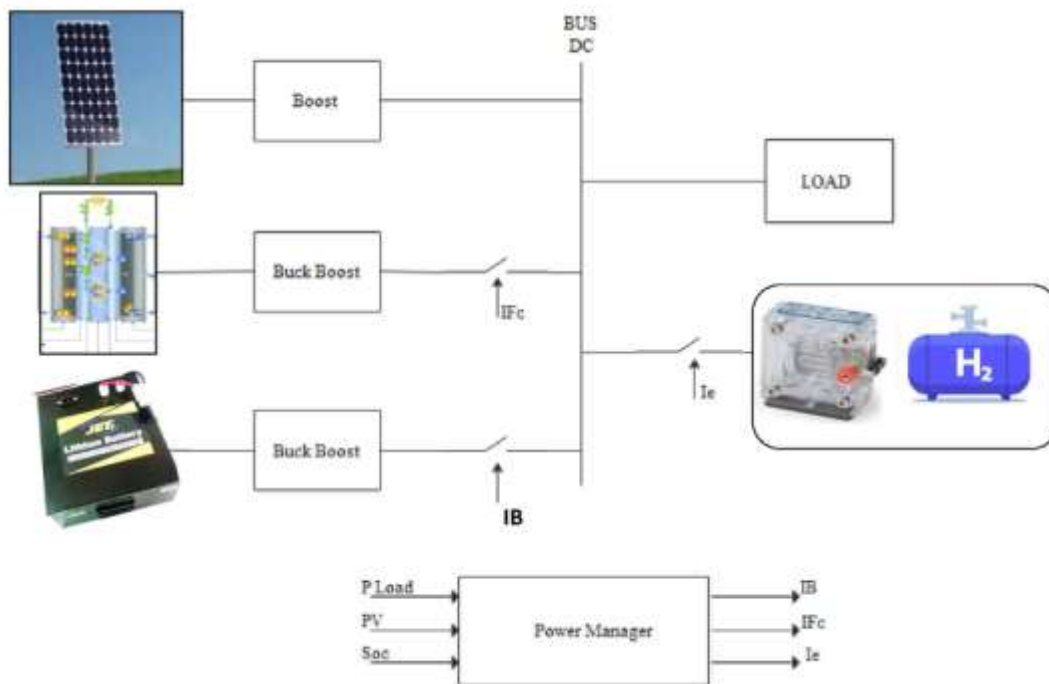

Figure 1. The complete PV-Battery fuel cell

## II.2. PV Model

Due to the physical process of the PV effect, solar energy conversion produces electrical energy. This behavior of a solar PV cell is similar to the P-N junction diode behavior [16].

The PV model used in this study is the Simulink-MATLAB model, as shown in Figure 2.

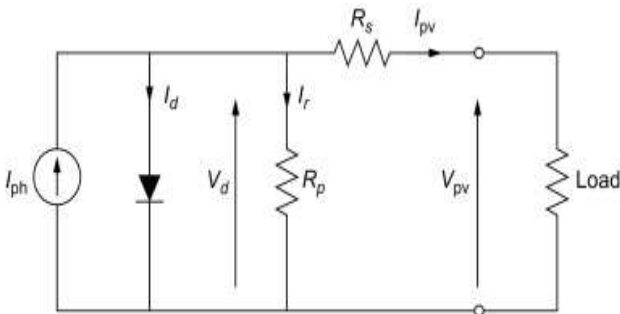

Figure 2. Solar Cell Model (Single Diode Equivalent Circuit)

The output voltage and the load current of a PV cell can be demonstrated by equation:

$$I = I_L - I_0 \left[ \exp\left(\frac{V_d + IR_s}{\alpha}\right) - 1 \right] \quad (5)$$

Where:  $I_L$  is the current of the PV cell (A) due to solar illumination;  $I_0$  the saturation current (A),  $I$  the load current (A);  $v$  the PV output voltage (V),  $R_s$  the series resistance of the PV cell ( $\Omega$ ),  $\alpha$  is the thermal voltage timing completion factor of the cell (V) [16].

$$\alpha = A \times N_s \times \frac{kT}{q} \quad (6)$$

Where:  $A$ : is the completion factor;  $k$ : is the Boltzmann's constant ( $0.38065 \times 10^{-23} \text{ J/K}$ );  $q$ : is the magnitude of charge of an electron  $1.6022 \times 10^{-19} \text{ C}$ ;  $T$ : is the cell temperature (K) and  $N_s$  the number of cells in series [16].

## II.3. Battery Model

There is a wide variety of batteries used in the Renewable Energy World; Lithium-ion batteries are the more used owing to their advantages. Lithium-ion batteries performance is preferable for stand-alone power systems [17] Therefore, this paper is a hybrid system with lithium-ion batteries.

In the MATLAB Simulink editor, a generic Li-ion battery model is improved and verified according to Shepherd's battery model [18-19] The modeling of the Li-ion battery is like a voltage-controlled source relying on the present state of charge SOC, therefore in this paper, the Simulink MATLAB generic Model

of Li-ion battery is used as shown in Figure 3.

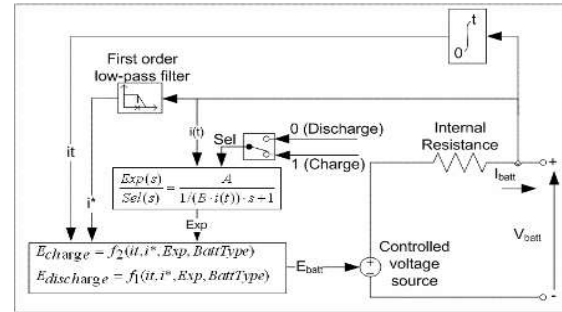

Figure 3. Li-ion battery MATLAB/Simulink Generic Model

For a Li-ion battery charging and discharging are governed by equations (7) and equation (8) [20].

For discharging ( $i > 0$ )

$$f_1(i, i^*, i) = E_0 - K \frac{Q}{Q - it} i^* - K \frac{Q}{Q - it} it + A \cdot \text{Exp}(-Bi) \quad (7)$$

For charging ( $i < 0$ ):

$$f_1(i, i^*, i) = E_0 - K \frac{Q}{it + 0.1Q} i^* - K \frac{Q}{Q - it} it + A \cdot \text{Exp}(-Bi) \quad (8)$$

Where:  $V_{Bat}$  is Nonlinear battery terminal voltage (V),  $E_0$  is: Constant or open circuit voltage (V),  $Exp(s)$  is: Exponential zone dynamics (V),  $Sel(s)$  is: Represents the battery mode,  $Sel(s) = 0$  during battery discharge,  $Sel(s) = 1$  during battery charging,  $K$  is: Polarization constant ( $Ah-1$ ) or polarization resistance (Ohms),  $i^*$ : Low frequency current dynamics (A),  $i$ : Battery current (A),  $it$ : Extracted battery capacity (Ah),  $Q$ : Maximum battery capacity (Ah),  $A$ : Exponential voltage (V),  $B$  is: Exponential capacity ( $Ah$ )-1 [20].

## III. Overview of the Stateflow

Stateflow is a visual environment of programming based on S finite state machines. Stateflow gives the ability to test and debug the design, think in the simulation of the different modes of operation, and generate a program from the state machine [21].

Using the Stateflow, the power management controller proposed in this paper is designed and is implemented, as shown in Figure 4.

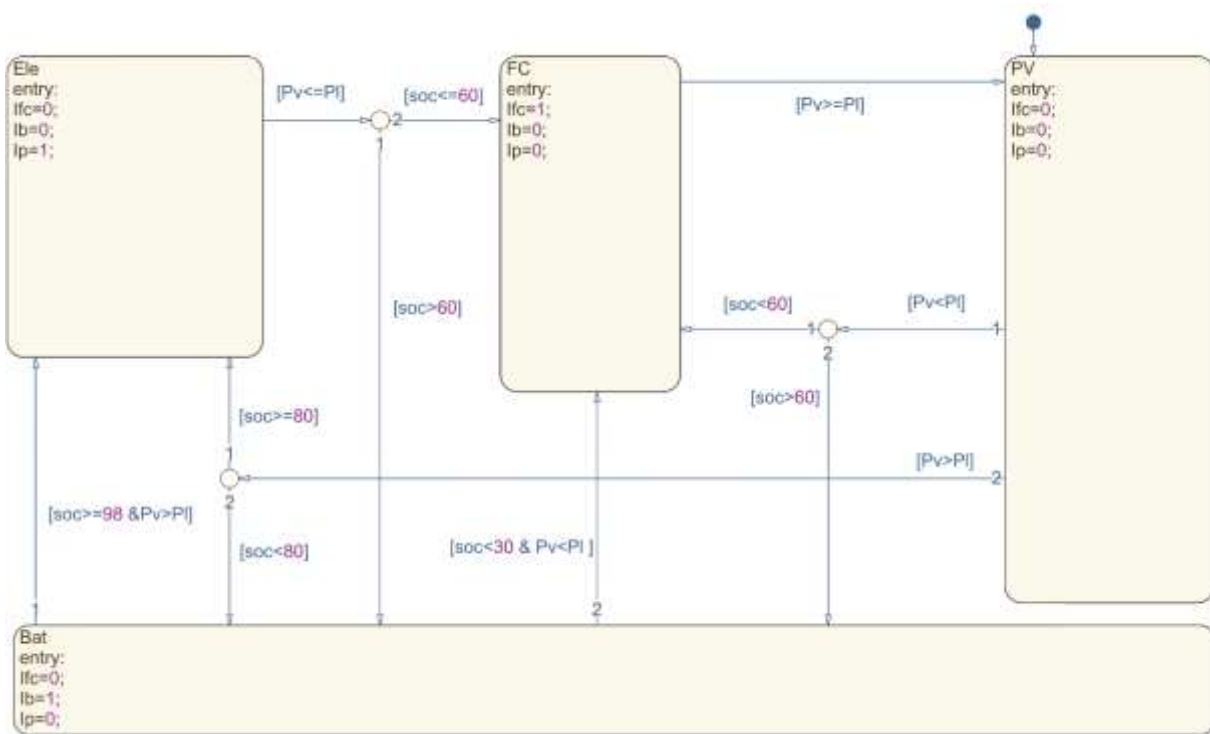

Figure 4. Stateflow chart of the Power Management Controller

The controller is simulated under the Simulink-MATLAB environment using Stateflow. The Simulink diagram of the controller is shown in Figure 5.

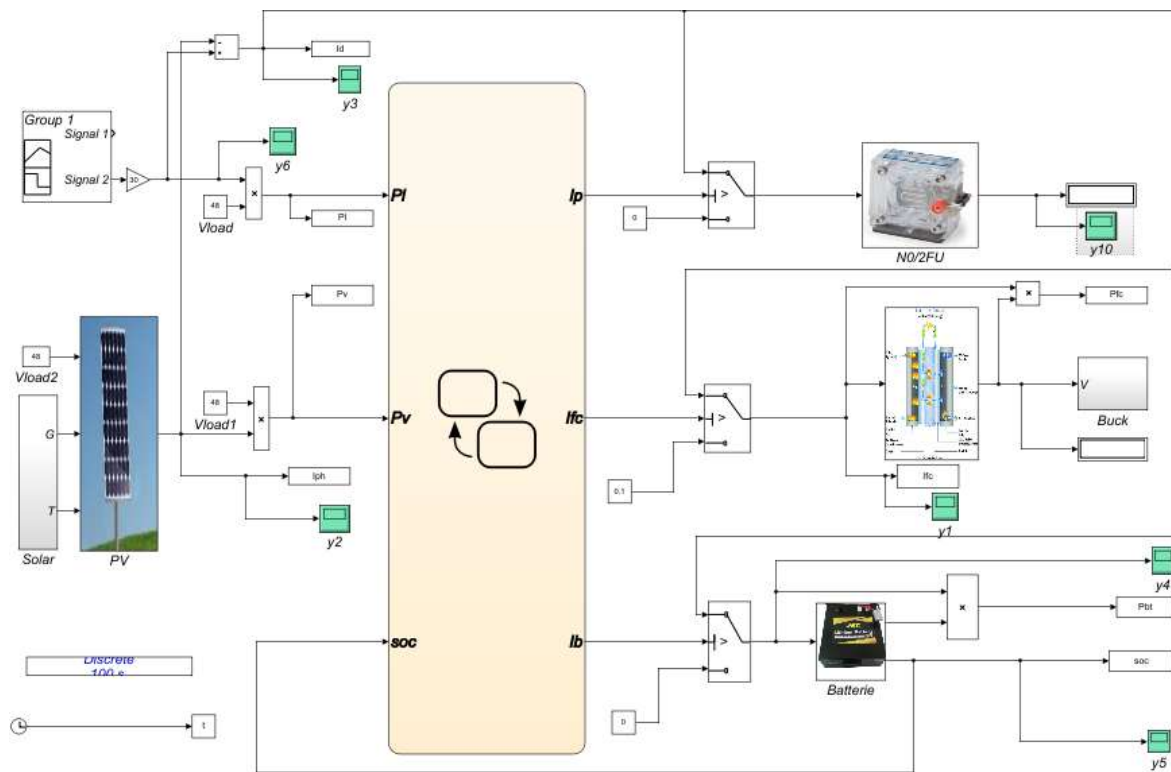

Figure 5. SIMULINK controller schematic

#### IV. Simulation results & discussion

The power management controller simulation operates for one day  $0 \leq t \leq 42.871 \times 10^3$  s, taking into consideration the state of charge of the battery (SOC level), the power between the PV power, and the consumption of the load under the following conditions:

1. Irradiance of 24 hours night and day in the province of BECHAR, a town situated in the south of Algeria, as shown in Figure 6.
2. 24-hours ambient temperature variation as indicated in Figure 7.
3. The Load demand current for one day, as shown in Figure 8.

For all the previous parameters and conditions, we obtain the following results:

1. Figure 09 shows the SOC and battery current.
2. The PEMFC current and hydrogen flow rate ( $qH_2$ ) are shown in Figure 10.
3. The output PV array current is shown in Figure 11.
4. Figure.12 shows photovoltaic power, battery power, load power consumption, and fuel cell power.

As discussed the controller operates according to the previous conditions throughout one day. the simulation results are shown in Figure 12. referring to Figure 12. There are five intervals that represent the different operating modes executed by the Power Management Controller under Matlab/Simulink using the State flow approach; they are:

##### The first interval

$$0 \leq t \leq 38.921 \times 10^3 \text{ s}$$

In this interval the Power management controller operates under the following conditions:

$$Pv < Pload$$

$$SOC < 60\%$$

The PV's output power is inferior to the fuel-cell power; therefore, the fuel-cell power satisfies the load demand while the battery is disconnected by the controller because the battery is deeply discharged  $SOC < 60\%$ , that's means:

$$Pload = Pv + Pfc \quad (9)$$

##### The second interval

For  $38.921 \times 10^3 \leq t \leq 42.871 \times 10^3$  s and under the following conditions:

- a.  $Pload < Pv$
- b.  $SOC < 80\%$

The PV's power is higher than the Load demand; in this case, the controller charges the battery using the PV surplus power, and we obtain:

$$Pload = Pv - Pbt \quad (10)$$

##### The third interval

In this mode, time interval is:

$$42.871 \times 10^3 \leq t \leq 47.172 \times 10^3 \text{ s}$$

The battery's SOC extends the maximum level greater than 98%, the controller disconnects the battery and connects the Electrolyzer to generate hydrogen in this case of PV's excess power, so:

$$Pload = Pv - Pelectrolyzer \quad (11)$$

##### The fourth interval

$$47.172 \times 10^3 \leq t \leq 64.472 \times 10^3 \text{ s}$$

In this mode the  $SOC > 60\%$  and load demand power is higher than the PV's power, the management system compensates the lack of load power demand from the battery as shown in equation:

$$Pload = Pv + Pbt \quad (12)$$

##### The fifth interval

For the last mode used by the Controller, the time interval is:  $64.472 \times 10^3 \leq t \leq 86.400 \times 10^3$  s .

The battery SOC falls under 30%, the controller disconnects the batteries and connects the fuel cell to satisfy the load power demand while PV power is minimal in this period of the day, the equation of load power demand is shown in this equation:

$$Pload = Pv + Pfc \quad (13)$$

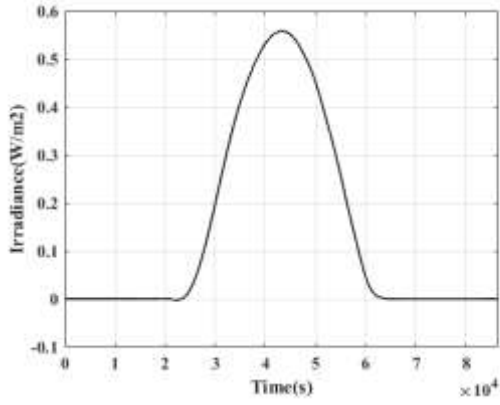

Figure 6. Irradiance  $G$  for one day (BECHAR-South of Algeria).

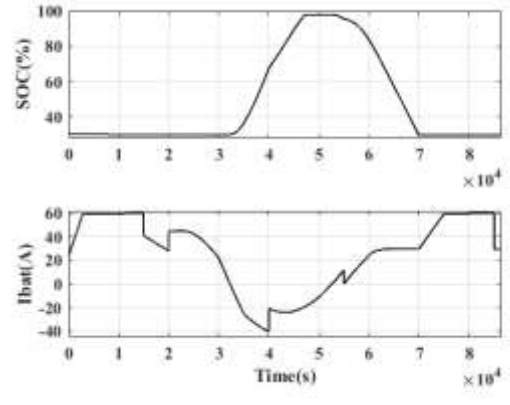

Figure 9. SOC and current of the battery.

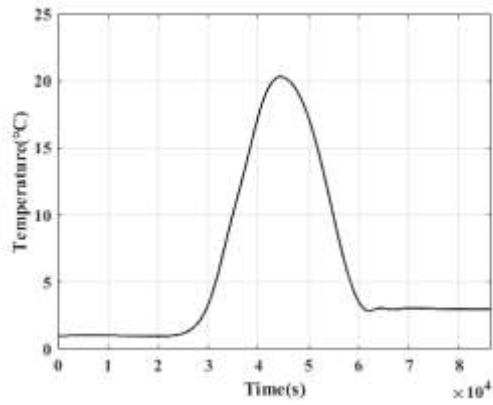

Figure 7. 24 Hours ambient temperature variation for one day (BECHAR location, south of Algeria).

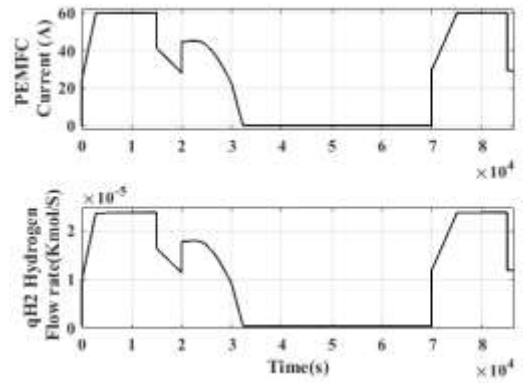

Figure 10. The current of the PEMFC and hydrogen flow rate  $qH_2$  variation.

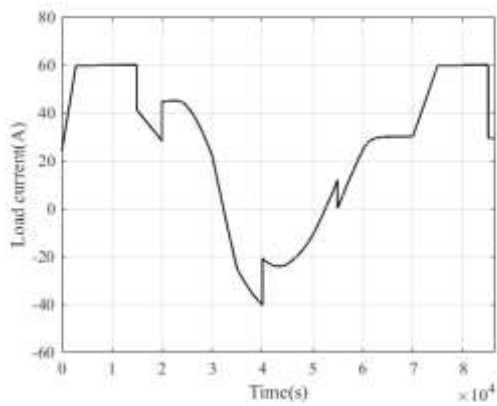

Figure 8. Load demand current

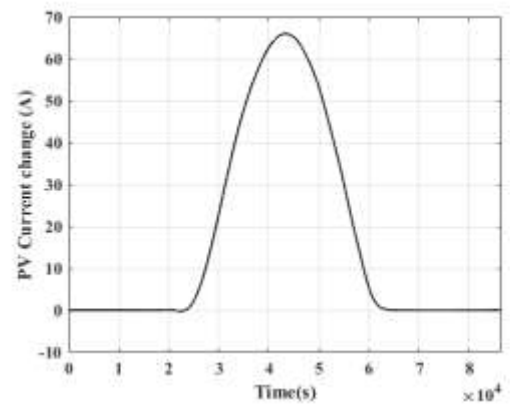

Figure 11. PV output current change

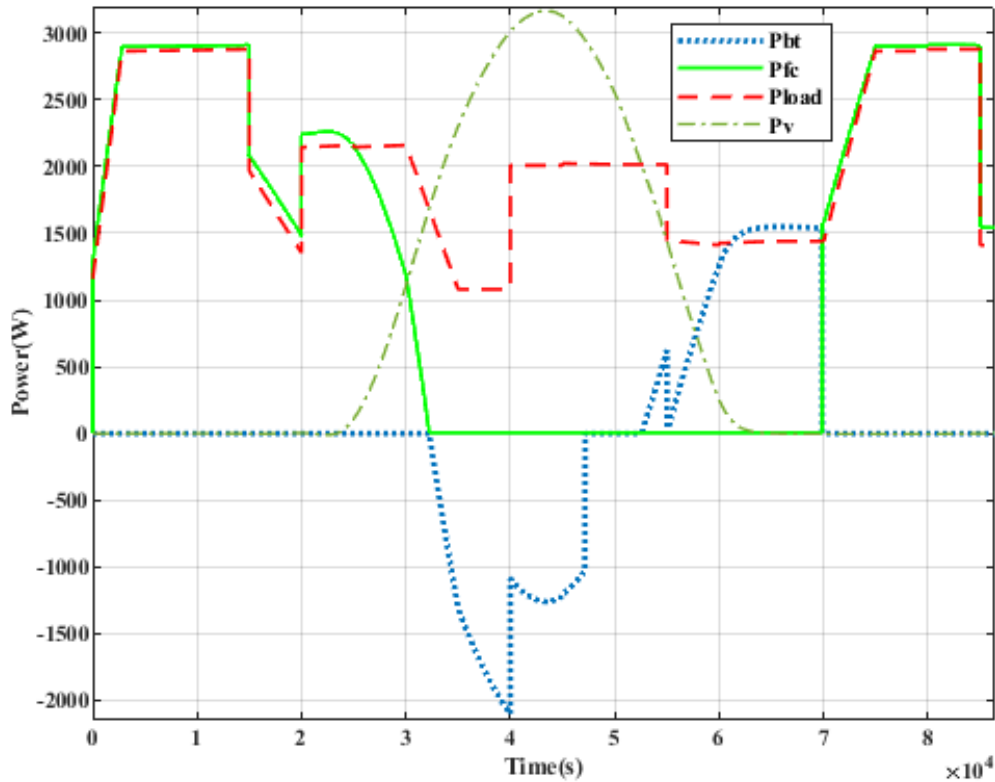

Figure 12. Power flow between the hybrid system sources

## V. Conclusion

In this article, the energy management controller controls a hybrid system, PEMFC, with a Lithium-Ion battery, PV and a DC load. The modeling of the studied system is under MATLAB-SIMULINK environment, applying the STATEFLOW approach to develop the system's controller.

The simulation results obtained in this article confirm successfully the efficiency of the suggested power management strategy.

The strategy used by the controller in this paper gives an easy scheme for power management and a practical code to implement in hardware.

This study can be proposed as a hybrid energy system for use in stand-alone power systems, for supplying oil well electric submersible pump, used in oil and gas facilities.

## Nomenclature

<i>Co2</i>	<i>Carbon Dioxide Emission</i>
<i>DC</i>	<i>Direct current</i>
<i>DC/DC</i>	<i>DC to DC Converter</i>
<i>FMI</i>	<i>finite state machines</i>
<i>G</i>	<i>Irradiance (W/m<sup>2</sup>)</i>
<i>Li-ion</i>	<i>Lithium- ion</i>
<i>PEMFC</i>	<i>Proton-Exchange Membrane Fuel-Cell</i>
<i>Pbt</i>	<i>Batterie power (W)</i>
<i>Pload</i>	<i>Load power (W)</i>
<i>Pv</i>	<i>Photovoltaic array</i>
<i>Pfc</i>	<i>Fuel cell's power (W)</i>
<i>qH2</i>	<i>Hydrogen flow rate (Mol/s)</i>
<i>SOC</i>	<i>State of charge of battery (%)</i>
<i>T</i>	<i>Temperature (°C)</i>
<i>Pload</i>	<i>Load power (W)</i>

## VI. References

1. Laribi, S.; Mammam, K.; Sahli, Y.; Koussa, K.; Air supply temperature impact on the PEMFC impedance. *Journal of Energy Storage* 17 (2018) 327–335.
2. Chi, J.; Yu, H.; Water electrolysis based on renewable energy for hydrogen production. *Cuihua Xuebao/Chinese Journal of Catalysis* 39 (2018) 390–394.
3. Mammam, K.; Laribi, S.; Application of adaptive neuro-fuzzy inference system techniques to predict water activity in proton exchange membrane fuel cell. *Journal of Electrochemical Energy Conversion and Storage* 15 (2018) 1–7.
4. Samson, T.; Tore, M.; Øystein, U.; Preben, J S.; Optimal load sharing strategy in a hybrid power system based on PV/fuel cell/ battery/supercapacitor. *2009 International Conference on Clean Electrical Power* 2027 (2009) 141–146.
5. Taner, T.; Alternative Energy of the Future: A Technical Note of PEM Fuel Cell Water Management. *Journal of Fundamentals of Renewable Energy and Applications* 05 (2015) 1–5.
6. Tran, M K.; Bhatti, A.; Vrolyk, R.; Wong, D.; Panchal, S.; Fowler, M.; Fraser, R.; A review of range extenders in battery electric vehicles: Current progress and future perspectives. *World Electric Vehicle Journal* 12 (2021) 12-54 .
7. Ceylan, C.; Devrim, Y.; Design and simulation of the PV/PEM fuel cell based hybrid energy system using MATLAB/Simulink for greenhouse application. *International Journal of Hydrogen Energy* 46 (2021) 22092–22106.
8. Kermadi, M.; Salam, Z.; Berkouk, E.; A Rule-based Power Management Controller using Stateflow for Grid-Connected PV-Battery Energy System supplying Household load. *2018 9th IEEE International Symposium on Power Electronics for Distributed Generation Systems, PEDG* (2018) 1–6.
9. Diaf, S.; Belhamel, M.; Haddadi, M.; Louche, A.; Technical and economic assessment of hybrid photovoltaic/wind system with battery storage in Corsica island. *Energy Policy* 36 (2008) 743–754.
10. Dursun, E.; Kilic, O.; Comparative evaluation of different power management strategies of a stand-alone PV/Wind/PEMFC hybrid power system. *Electrical Power and Energy Systems* 36 (2008) 81–89.
11. Şahin, M E.; Okumuş, H. I.; Aydemir, M. T.; Implementation of an electrolysis system with DC/DC synchronous buck converter. *International Journal of Hydrogen Energy* 39 (2014) 6802–6812.
12. Boussaid, B.; Harrouz, A.; Benmenine, D.; Tahiri, F.; Bekraoui, F.; Optimal PI Parameters Tuning for a DC-DC Boost Converter. *Algerian Journal of Renewable Energy and Sustainable Development* 3 (2021) 223–229.
13. Mammam, K.; Saadaoui, F.; Hazzab, A.; Development and simulation of a PEM fuel cell model for prediction of water content and power generation. 4 (2018) 289–299.
14. Laribi, S.; Mammam, K.; Arama, F. Z.; Ghaitaoui, T.; Analyze of Impedance for Water Management in Proton Exchange Membrane Fuel Cells Using Neural Networks Methodology. *Algerian Journal of Renewable Energy and Sustainable Development* 01 (2019) 69–78.
15. Dash, V.; Bajpai, P.; Power management control strategy for a stand-alone solar photovoltaic-fuel cell-battery hybrid system. *Sustainable Energy Technologies and Assessments* 9 (2015) 68–80.
16. Nehrir, M. H. ; Wang, C.; Modeling and control of fuel cells: Distributed generation applications. *A John Wiley & Sons, Inc., publication* (2009) 1–296.
17. Mane, S.; Kadam, P.; Lahoti, G.; Kazi, F.; Singh, N. M.; Optimal load balancing strategy for hybrid energy management system in DC microgrid with PV, fuel cell and battery storage. *2016 IEEE International Conference on Renewable Energy Research and Applications, ICRERA 2016* 5 (2016) 851–856.
18. Mathworks.com ;Charge and Discharge Characteristics. <https://www.mathworks.com/help/physmod/sps/powersys/ref/battery.html> (2019) 1–16.
19. Baboselac, I.; Benšić, T.; Hederić, Ž.; MatLab simulation model for dynamic mode of the Lithium-Ion batteries to power the EV. *Technical Journal* 11 (2017) 7–13.
20. Wijewardana, S. M.; New Dynamic Battery Model for Hybrid Vehicles and Dynamic Model Analysis Using Simulink. *Engineer: Journal of the Institution of Engineers* 47 (2014) 53-61.
21. The MathWorks, Matlab and Simulink; I. Getting Started Guide ;Stateflow ; R2020 b. (2020) 1-66.

**Please cite this Article as:**

Hanafi Y., Mammam K., Power Management of Hybrid System (PEMFC/PV/ Lithium-ion Batteries) Using State flow, *Algerian J. Env. Sc. Technology*, 9:3 (2023) 3272-3279